

AIR 23 C12A

HIGH EFFICIENCY AIR/WATER HEAT PUMP
INCL. HORIZONTAL SPLIT EVAPORATOR

ORDER NUMBER: 287040
SERIES: M4
TF MAX. 65 °C
SPLIT

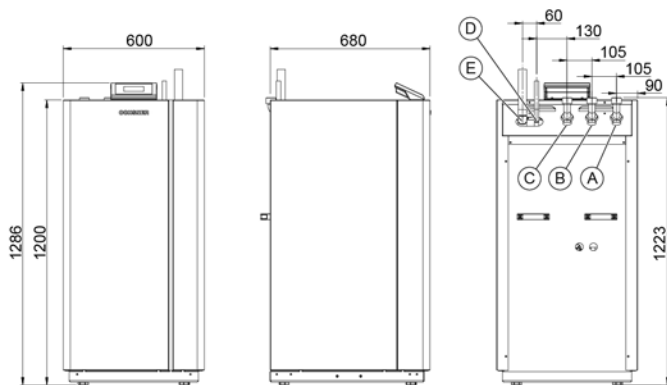

(A) FLHC (outlet) (B) FLT (outlet) (C) RTN (inlet) (D) WQA (outlet) (E) WQA (inlet)

APPLIANCE DATA

Dimensions HxWxD	[mm]	1285x600x681
Hydraulic connection	[inch]	1 1/2"
Weight	[kg]	148
Casing colour		White/anthracite

HEATING MODE PERFORMANCE FIGURES (to EN 14511)

Standard point A10/W35

Heating output	[kW]	23,40
Total power consumption / operating current	[kW]/[A]	4.60 / 9.00
COP		5,10

Operating point A7/W35

Heating output	[kW]	20,70
Total power consumption / operating current	[kW]/[A]	4.50 / 8.80
COP		4,60

Standard point A2/W35

Heating output	[kW]	17,20
Total power consumption / operating current	[kW]/[A]	4.10 / 8.00
COP		4,20

Standard point L-7/W35

Heating output	[kW]	13,70
Total power consumption / operating current	[kW]/[A]	3.90 / 7.60
COP		3,50

Operating point L-10/W35

Heating output	[kW]	12,80
Total power consumption / operating current	[kW]/[A]	3.90 / 7.60
COP		3,30

Operating point A2/W50

Heating output	[kW]	16,80
Total power consumption / operating current	[kW]/[A]	5.30 / 10.30
COP		3,20

Operating point A2/W60

Heating output	[kW]	16,40
Total power consumption / operating current	[kW]/[A]	5.80 / 11.30
COP		2,80

COOLING MODE PERFORMANCE FIGURES

Operating point A30/W18

Cooling capacity	[kW]	15,60
Total power consumption / operating current	[kW]/[A]	5.10 / 9.90
Energy efficiency ratio EER		3,10

Operating point A30/W7

Cooling capacity	[kW]	15,20
Total power consumption / operating current	[kW]/[A]	5.00 / 9.80
Energy efficiency ratio EER		3,00

Hydraulic version			Electric immersion heater		3-way switching module	
			Internal	external	Internal	external
M2-1	M4-1		x		x	
M2-2	M4-2			x	x	
M2-3	M4-3		x			x
M2-4	M4-4	M6		x		x

SPECIFICATION

Phases/nominal voltage/frequency	[~]/[V]/[Hz]	3/400/50
Output factor cos φ		0,74
Fuse protection (tripping curve "C")	[A]	20
Max. operating current	[A]	16,80
Max. starting current/max. with soft start	[A]	101.00 / 50.50
Sound power/sound pressure level (at 1 m distance) indoor unit	[dBA]	49.50 / 41.50
Sound power/sound pressure level (at 10 m distance), outdoor unit	[dBA]	54.0 / 26.0

CONDENSER

Type		Plate heat exchanger
Material		Stainless steel 1.4301
Max. refrigerant operating pressure	[bar]	30
Max. heat transfer medium operating pressure	[bar]	3
Heat transfer medium temperature differential	[K]	5
Application range	[°C]	65
Heat transfer medium		Water
Test pressure	[bar]	45
Heat transfer medium flow rate	[m³/h]	3,40
Internal pressure differential	[mbar]	330
Flow meter (FM)	Internal	Installed as
Circulation pump heat sink (WNA)	Internal	Stratos Para 25/1-8
Residual head I WNA external	[mbar]	356 (M4-1) 452 (M4-4)

REFRIGERANT CIRCUIT

Refrigerant		R407C
Defrost technology		Hot gas
Refrigerant charge	[kg]	10

COMPRESSOR

Type		Scroll
Output levels		1
Speed	[rpm]	2900
Voltage/frequency	[V]/[Hz]	400/50

FAN

Type		axial
Number	[pce]	2
Voltage/frequency	[V]/[Hz]	230/50
Power consumption	[W]	1 x 111
Max. operating current	[A]	1 x 2.80

EVAPORATOR

Unit type		VHS-M 19
Dimensions HxWxD	[mm]	1080x2220x960
Type		Finned pipe
Number	[pce]	1
Weight	[kg]	136
Fin pack material		Copper/aluminium
Casing material		Stainless steel / coated
Max. refrigerant operating pressure	[bar]	30
Relative humidity	[%]	80
Heat transfer medium temperature differential	[K]	4,00
Air flow rate	[m³/h]	8000
Application range min./max	[°C]	-22 / 40



SPLIT EVAPORATOR VHS-M 19

RECOMMENDED ACCESSORIES

	Order no./type	Description	Pressure loss
Heat pump separating cylinders	min. PU500	30 l/kW at L2/W35	-
DHW tank	min. SP500	30 l/kW at L2/W50	-
External plate heat exchanger (DHW heating)	911252 PHE 5007	Prim.: 1 1/4" Sec.: 1"	Prim.: 37 mbar Sec.: 48 mbar
3-way switching module internal	980191	-	18 mbar
3-way switching module external	290341	DN40 (1 1/2") kvs 25	18 mbar
Electric immersion heater internal	980190	8.8 kW (2.6 / 3.0 / 3.2)	81 mbar
External electric immersion heater (heat pump buffer tank)	922509	9 kW	-

Application	Booster heater output
Bivalent parallel	Sizing according to calculated value (offer program), but with minimum 50% of building heat load
Bivalent partial parallel	Sizing to 100% of building heat load
Bivalent alternative	Sizing to 100% of building heat load

	Max. connection length	Max. height differential
AIR 23 C12A	Lmax ≤ 20	Hmax ≤ 10

LIMITS OF USE AIR 23 C12A

Outdoor temperature/max. heat pump flow temperature	A-10/W65°C A-15/W60°C A-20/W55°C
Underfloor heating (-15°C / 35°C)	YES
Radiators (-15°C / 50°C)	YES
Radiators (-15°C / 55°C)	YES
Radiators (-15°C / 65°C)	YES
Radiators (-15°C / 65°C)	Booster heater should be sized for 100% heat load
Domestic hot water	YES

PERFORMANCE CURVES AIR 23 C12A

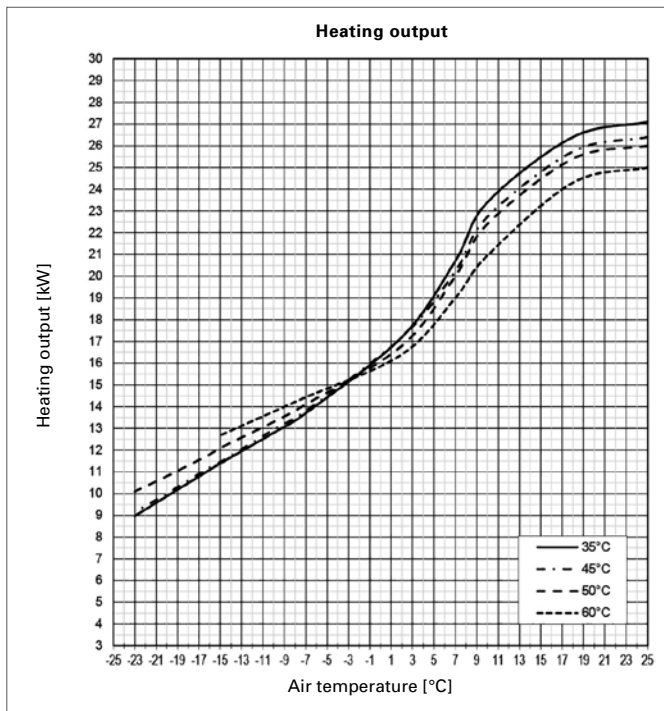

PRODUCT DATA ErP: AIR 23 C12A

	COLDER	MEAN	HOTTER
LOW TEMPERATURE	A++	35°C	
ηs	161	174	199
Energy consumption [kWh]	6821	7236	4558
P rated [kW]	11	16	17
SCOP	4,11	4,43	5,04
MEDIUM TEMPERATURE	A++	55°C	
ηs	123	136	157
Energy consumption [kWh]	9740	9600	5563
P rated [kW]	12	16	17
SCOP	3,15	3,46	3,99
DHW	A	SP500	
ηWH	94	103	119
Energy consumption [kWh]	1478	1351	1172
Draw-off profile		XL	
Tank losses [W]		117	
		indoor	outdoor
Sound power level [dBA]		49,5	54,0
Controller class with room remote control	VII	Controller contribution [%]	3,5
Controller class without room remote control	III	Controller contribution [%]	1,5

